

Preface

Thank you for purchasing the AC900 series AC drive.

The AC900 series AC drive is a general-purpose high-performance current vector control AC drive. It is used to drive various automation production equipment involving textile, paper-making, wiredrawing, machine tool, packing, food, fan and pump.

This manual describes the correct use of the AC900 series AC drive, including selection, parameter setting, commissioning, maintenance & inspection. Read and understand the manual before use and forward the manual to the end user.

Notes

- The drawings in the manual are sometimes shown without covers or protective guards. Remember to install the covers or protective guards as specified first, and then perform operations in accordance with the instructions.
- The drawings in the manual are shown for description only and may not match the product you purchased.
- The instructions are subject to change, without notice, due to product upgrade, specification modification as well as efforts to increase the accuracy and convenience of the manual.
- Contact our agents or customer service center if you have problems during the use. Phone number:400-886-9116

Connection to peripheral devices

Use within the allowable power supply specification of the AC drive.

Select a proper breaker to resist large in-rush current that flows into the AC

To guarantee safety, use an electromagnetic contactor. Do not use it to start or stop the AC drive

Suppress the high order harmonic to

Noise filter on input side

AC900 AC drive

Ground

Reliably ground the motor and the

Motor

Ground

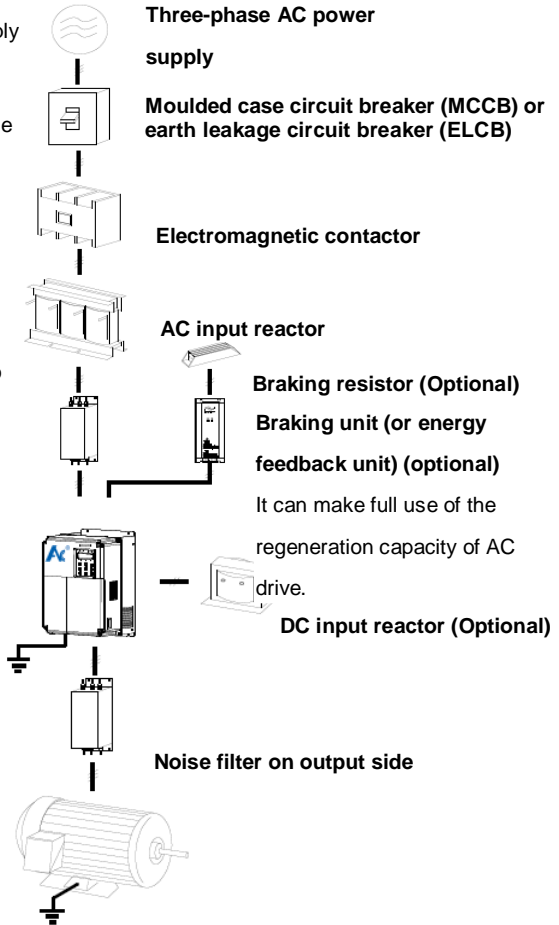

Notice:

- Do not install the capacitor or surge suppressor on the output side of the AC drive. Otherwise, it may cause faults to the AC drive or damage to the capacitor and surge suppressor.
- Inputs/Outputs (main circuit) of the AC drive contain harmonics, which may interfere with the communication device connected to the AC drive. Therefore, install an anti-interference filter to minimize the interference.
- For more details on peripheral devices, refer to related selection manual.

Contents

Preface.....	1
Connection to peripheral devices.....	2
Contents.....	3
1 Product Information.....	4
Safety Information and Precautions.....	4
1.1 Designation Rules.....	4
1.2 Nameplate.....	4
1.3 AC900 AC Drive Series Index.....	5
1.4 Physical Appearance and Overall Dimensions.....	7
1.5 Main Circuit Terminals and Wiring.....	10
1.6 Wiring Mode of the AC Drive Control Circuit.....	11
1.7 Description of Control Circuit Terminals.....	11
1.8 Function Description of Control Circuit Terminals.....	13
Description of Wiring of Signal Terminals:.....	14
2 Operation, Display and Application Examples.....	15
2.1 Operation and Display Panel.....	15
3 Function Code Tables.....	17
3.1 Standard Function Parameters.....	18
3.2 Monitoring Parameters.....	48
4 Troubleshooting and Resolutions.....	50
4.1 Faults and solutions.....	50
4.2 Common Faults and Solutions.....	55
Appendix AC900 Modbus Communication Protocol.....	57
Warranty Agreement.....	61
Warranty Card.....	62

1 Product Information

Safety Information and Precautions

In this manual, the notices are graded based on the degree of danger:

 **DANGER** indicates that failure to comply with the notice will result in severe personal injury or even death.

 **WARNING** indicates that failure to comply with the notice will result in personal injury or property damage.

Read this manual carefully so that you have a thorough understanding. Installation, commissioning or maintenance may be performed in conjunction with this chapter. Our company will assume no liability or responsibility for any injury or loss caused by improper operation.

1.1 Designation Rules

Figure 1-1 Designation rules

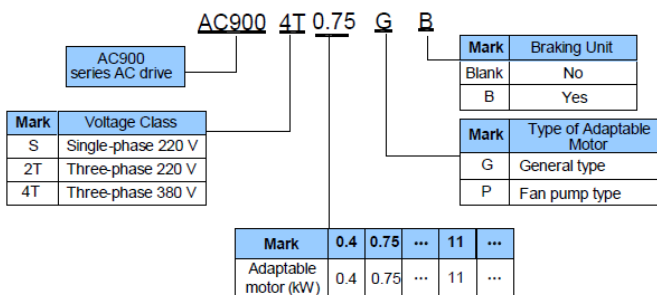

1.2 Nameplate

Figure1-2 Nameplate

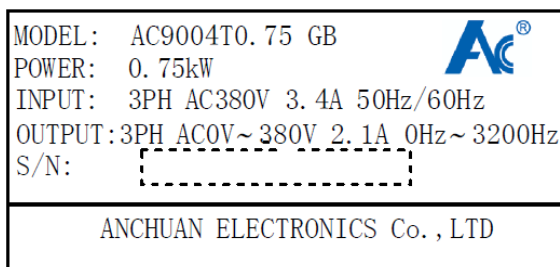

1.3 AC900 AC Drive Series Index

Table 1-1 AC drive model and technical data

AC drive model	Power capacity(kVA)	Input current A	Output current A	Adaptable Motor	
				kW	HP
Single-phase power: 220V, 50/60Hz					
AC900-S0.75GB	1.5	8.2	4.0	0.75	1
AC900-S1.5GB	3.0	14.0	7.0	1.5	2
AC900-S2.2GB	4.0	23.0	9.6	2.2	3
Three-phase power:220V, 50/60Hz					
AC900-2T0.75GB	3	5	3.8	0.75	1
AC900-2T1.5GB	4	5.8	5.1	1.5	2
AC900-2T2.2GB	5.9	10.5	9	2.2	3
AC900-2T3.7GB	8.9	14.6	13	3.7	5
AC900-2T5.5GB	17	26	25	5.5	7.5
AC900-2T7.5GB	21	35	32	7.5	10
AC900-2T11G	30	46.5	45	11	15
AC900-2T15G	40	62	60	15	20
AC900-2T18.5G	57	76	75	18.5	25
AC900-2T22G	69	92	91	22	30
AC900-2T30G	85	113	112	30	40
AC900-2T37G	114	157	150	37	50
AC900-2T45G	134	180	176	45	60
AC900-2T55G	160	214	210	55	75
AC900-2T75G	231	307	304	75	100
Three-phase power: 380V, 50/60Hz					
AC900-4T0.75GB	1.5	3.4	2.1	0.75	1
AC900-4T1.5GB	3.0	5.0	3.8	1.5	2
AC900-4T2.2GB	4.0	5.8	5.1	2.2	3
AC900-4T3.0GB	5.0	8.0	7.0	3.0	4
AC900-4T4.0GB	5.9	10.5	9.0	4.0	5
AC900-4T5.5GB	8.9	14.6	13.0	5.5	7.5
AC900-4T7.5GB	11.0	20.5	17.0	7.5	10
AC900-4T11GB	17.0	26.0	25.0	11.0	15
AC900-4T15GB	21.0	35.0	32.0	15.0	20
AC900-4T18.5GB	24.0	38.5	37.0	18.5	25
AC900-4T22G	30.0	46.5	45.0	22	30

AC900-4T30G	40.0	62.0	60.0	30	40
AC900-4T37G	57.0	76.0	75.0	37	50
AC900-4T45G	69.0	92.0	91.0	45	60
AC900-4T55G	85.0	113.0	112.0	55	70
AC900-4T75G	114.0	157.0	150.0	75	100
AC9004T90G	134	180	176	90	125
AC9004T110G	160	214	210	110	150
AC9004T132G	192	256	253	132	175
AC9004T160G	231	307	304	160	250
AC9004T200G	250	385	377	200	300
AC9004T220G	280	430	426	220	300
AC9004T250G	355	468	465	250	400
AC9004T280G	396	525	520	280	370
AC9004T315G	445	590	585	315	500
AC9004T355G	500	665	650	355	420
AC9004T400G	565	785	725	400	530
AC9004T450G	630	883	820	450	600

Table 1-2 Housing type of AC900 series are as below:

Type	Housing type
Single-phase 220V	
0.75kW ~ 2.2kW	Plastic housing
Three-phase 220V	
0.75kW ~ 11kW	Plastic housing
15kW ~ 75kW	Sheet metal housing
Three-phase 380V	
0.75kW ~ 18.5kW	Plastic housing
22kW ~ 400kW	Sheet metal housing

1.4 Physical Appearance and Overall Dimensions

1.4.1 Physical Appearance

Figure 1-3 Physical appearance and overall dimensions of AC900 (plastic housing)

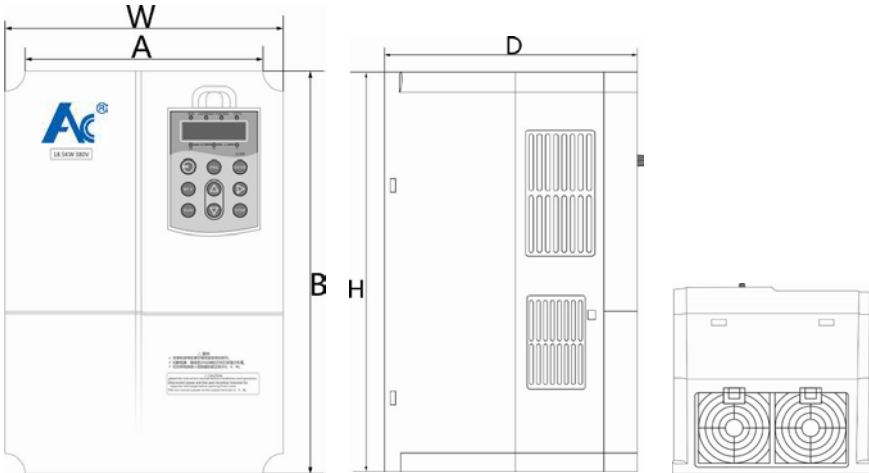
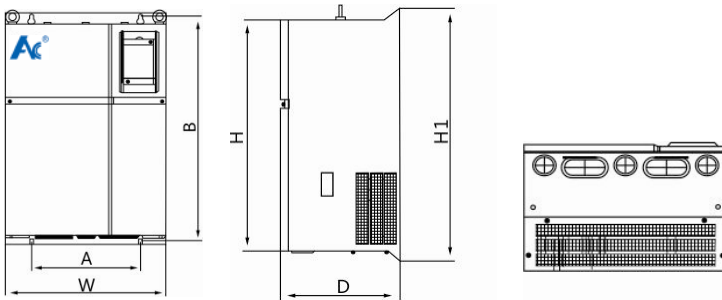

Figure 1-4 Physical appearance and overall dimensions of AC900 (sheet metal housing)



1.4.2 Physical Appearance and Mounting Hole Dimensions of AC900 (mm)

Table 1-3 Appearance and Mounting Hole Dimensions of AC900

Model	Mounting hole (mm)		Overall dimension (mm)				Mounting Hole Diameter (mm)	Weight (kg)
	A	B	H	H1	W	D		
Single-phase 220V Structure A/B								
AC900S0.75GB	73	130	142	/	85	127	Ø4.5	1.2
AC900S1.5GB	94	150	161	/	105	146	Ø5.0	1.4
AC900S2.2GB	These four models support A, B structures. Dimensions of these two structures are as above.							
Three-phase 220V Structure A/B								
AC9002T0.75GB	73	130	142	/	85	127	Ø4.5	1.2
AC9002T1.5GB	94	150	161	/	105	146	Ø5.0	1.4
AC9002T2.2GB	These four models support A, B structures. Dimensions of these two structures are as above.							
AC9002T4.0GB	137	232	247	/	152	183	Ø5	3.0
AC9002T5.5GB								
AC9002T7.5GB	204	308	323	/	220	213	Ø6	6.2
AC9002T11G								
AC9002T15G	235	449	432	465	286	231	Ø6.5	17
AC9002T18.5G								
AC9002T22G	220	465	431	485	306	241	Ø9	23
AC9002T30G								
AC9002T37G	219	580	553	600	325	282	Ø9	33
AC9002T45G								
AC9002T55G	315	653	626	673	425	316	Ø10	45
AC9002T75G	405	720	696	746	498	333	Ø9	63
Three-phase 380V Structure A/B								
AC9004T0.75GB	73	130	142	/	85	127	Ø4.5	1.2
AC9004T1.5GB	94	150	161	/	105	146	Ø5.0	1.4
AC9004T2.2GB	These three models support A, B structures. Dimensions of these two structures are as above.							

AC9004T4.0GB	116	174	188	/	127	168	Ø 5.0	1.8
AC9004T5.5GB	137	232	247	/	152	183	Ø 5.0	3.0
AC9004T7.5GB								
AC9004T11GB								
AC9004T15GB	204	308	323	/	220	213	Ø 6.0	6.2
AC9004T18.5GB								
AC9004T22GB								
AC9004T30GB	223	404	382	420	261	197	Ø 7	13
AC9004T37GB								
AC9004T45GB	220	465	431	485	306	241	Ø9	23
AC9004T55GB								
AC9004T75GB	219	580	553	600	325	282	Ø9	33
AC9004T90G								
AC9004T110G								
AC9004T132G	315	653	626	673	425	316	Ø10	45
AC9004T160G								
AC9004T185G	426	735	707	760	526	318	Ø10	70
AC9004T200G								
AC9004T220G								
AC9004T250G	426	850	826	876	536	350	Ø10	96
AC9004T280G								
AC9004T315G	407	1149	1051	1207	687	407	Ø16	130
AC9004T355G								
AC9004T400G								
AC9004T450G								
AC9004T450G								

1.4.3 Dimensions of Operation Panel

Figure1-5 Dimensions of operation panel

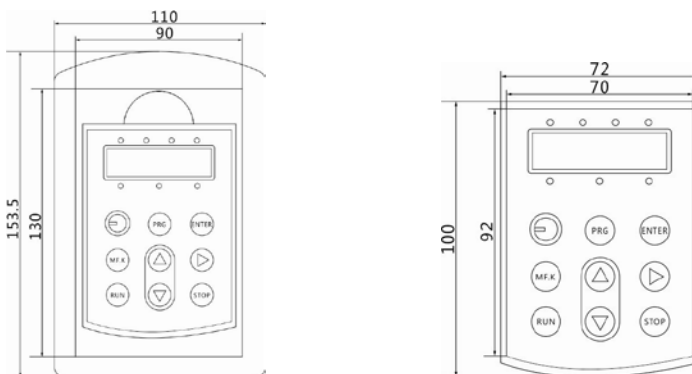

1.5 Main Circuit Terminals and Wiring

1) Description of main circuit terminals of single-phase AC drive

Terminal	Name	Description
L、N	Single-phase power supply input terminals	Connect to the single-phase 220 VAC power supply
(+)、(-)	Positive and negative	Common DC bus input point
P+、PB	Connecting terminals of braking	Connect to a braking resistor
U、V、W	AC drive output terminals	Connect to a three-phase motor
PE 	Grounding terminal	Must be grounded

2) Description of main circuit terminals of three-phase AC drive

Terminal	Name	Description
R、S、T	Three-phase power supply input terminals	Connect to the three-phase AC power supply
(P+)、(P-)	Positive and negative terminals of DC bus	Common DC bus input point Connect the external braking unit to the AC drive of 18.5 kW and above (220 V) and 37 kW and above (other voltage classes).
P+、PB	Connecting terminals of braking resistor	Connect to the braking resistor for the AC drive of 15 kW and below (220 V) and 30 kW and below (other voltage classes).
P、(P+)	Connecting terminals of external reactor	Connect to an external reactor.
U、V、W	AC drive output terminals	Connect to a three-phase motor.
PE 	Grounding terminal	Must be grounded.

1.6 Wiring Mode of the AC Drive Control Circuit

Figure 1-6 Wiring mode of the AC drive control circuit

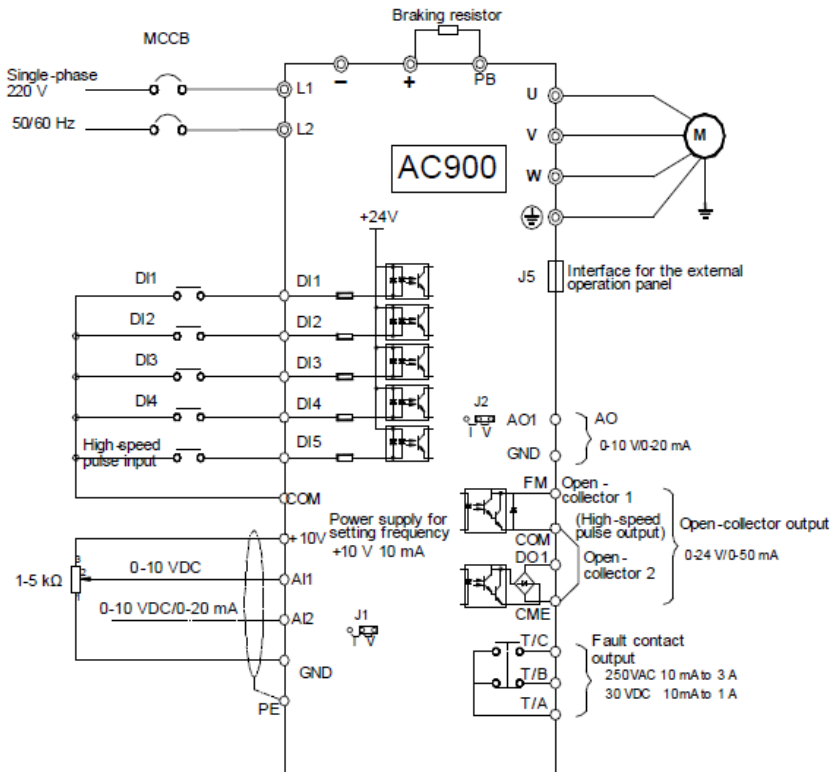

- Note: All AC900 series AC drives have the same wiring mode. The figure here shows the wiring of three-phase 380 V AC drive. © indicates main circuit terminal, while ○ indicates control circuit terminal.

1.7 Description of Control Circuit Terminals

Terminal Arrangement of Control Circuit Terminal is as below:

Figure 1-7 Terminal Arrangement of Control Circuit

+10V	AI1	AI2	GND	DI1	DI2	DI3	DI4	DI5	COM		T/A
GND	AO1	A+	B-	DO1	FM	COM	COM	+24V		T/B	T/C

Figure 1-8 Terminal Arrangement of A Control Circuit

24V	DO1	FM	COM	+10V	GND	A01	GND	AI1	
	T/A	T/C	DI1	DI2	DI3	DI4	COM	A+	B-

1.8 Function Description of Control Circuit Terminals

Table 1-4 Function Description of control circuit terminals of AC900

Type	Terminal	Name	Function Description
Power supply	+10V-GND	External +10 V power supply	Provide +10 V power supply to external unit. Generally, it provides power supply to external potentiometer with resistance range of 1-5k Ω . Maximum output current:10mA
	+24V-COM	External +24 V power supply	Provide +24 V power supply to external unit. Generally, it provides power supply to DI/DO terminals and external sensors. Maximum output current:200mA
Analog input	AI1-GND	Analog input 1	Input voltage range: 0-10 VDC Impedance: 22k Ω
	AI2-GND	Analog input 2	Input range: 0-10 VDC/0-20mA, decided by jumper J1 on the control board Impedance: 22k Ω (voltage input),500 Ω (current input)
Digital input	DI1- COM	Digital input 1	Optical coupling isolation Impedance: 2.4k Ω Voltage range for level input: 9-30V
	DI2- COM	Digital input 2	
	DI3- COM	Digital input 3	
	DI4- COM	Digital input 4	
	DI5- COM	High-speed pulse input	Besides features of DI1-DI4, it can be used for high-speed pulse input. Maximum input frequency: 100 kHz
Analog output	AO1-GND	Analog output 1	Voltage or current output is decided by jumper J2. Output voltage range: 0-10V Output current range: 0-20mA
Digital output	DO1-COM	Digital output 1	Optical coupling isolation, dual polarity open collector output Output voltage range: 0-24V Output current range: 0-50mA
	FM- COM	High-speed pulse output	It is limited by P5-00 (FM terminal output mode selection). As high-speed pulse output, the maximum frequency hits 100 kHz. As open-collector output, its specification is the same as that of DO1
Relay output	T/A-T/B	NC terminal	Contact driving capacity: 250VAC, 3A, COS ϕ =0.4 30VDC, 1A Applying to Overvoltage Category II circuit
	T/A-T/C	NO terminal	
Auxiliary interface	J3	485 communication	Jumper selection to decide whether to connect 330 Ω matched resistor to make 485 communication
	J5	External operation panel interface	Connect to external operation panel.

Description of Wiring of Signal Terminals:

Wiring of AI terminals:

Weak analog voltage signals are easy to suffer external interference, and therefore the shielded cable must be used and the cable length must be less than 20 m. In applications where the analog signal suffers severe interference, install filter capacitor or ferrite magnetic core at the analog signal source.

2 Operation, Display and Application Examples

2.1 Operation and Display Panel

You can modify the parameters, monitor the working status and start or stop the AC900 by operating the operation panel, as shown in the following figure.

Figure 2-1 operation panel

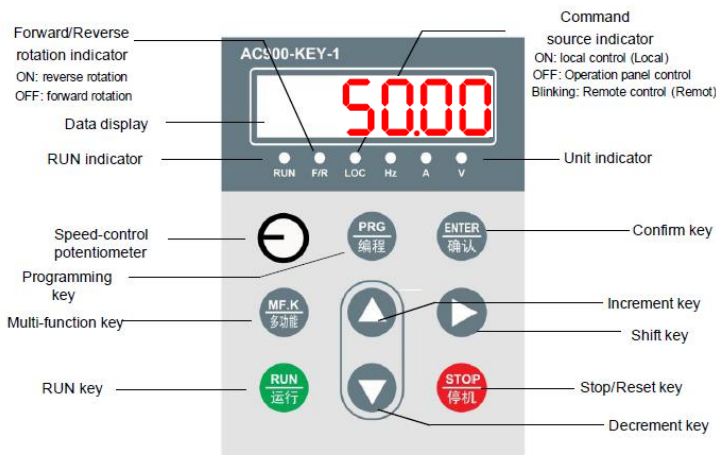

1) Description of Indicators

- RUN: ON indicates that the AC drive is in the running state, and OFF indicates that the AC drive is in the stop state.
- LOCAL/REMOT: It indicates whether the AC drive is operated by means of operation panel, terminals or communication.

○ LOCAL/REMOT: OFF	Operation panel control
● LOCAL/REMOT: ON	Terminal control
◐ LOCAL/REMOT: blinking	Communication control

- FWD/REV: ON indicates reverse rotation, and OFF indicates forward rotation.
- TUNE/TC: When the indicator is ON, it indicates torque control mode. When the indicator is blinking slowly, it indicates the auto-tuning state. When the indicator is blinking quickly, it indicates the fault state.

2) Unit Indicators

● means that the indicator is ON, and ○ means that the indicator is OFF.

● Hz	○ A	○ V	: Hz(unit of frequency)
○ Hz	● A	○ V	: A (unit of current)
○ Hz	○ A	● V	: V(unit of voltage)
● Hz	● A	○ V	: RMP(unit of rotational speed)
○ Hz	● A	● V	: %(percentage)

3) Data Display

The 5-digit LED display is able to display the set frequency, output frequency, monitoring data and fault codes.

4) Description of keys on the operation panel

Table 2-1 Description of keys on the operation panel

Key	Name	Function
PRG	Programming	Enter or exit Level I menu.
ENTER	Confirm	Enter the menu interfaces level by level, and confirm the parameter setting.
△	Increment	Increase data or function code
▽	Decrement	Decrease data or function code
▶	Shift	Select the displayed parameters in turn in the stop or running state, and select the digit to be modified when modifying parameters.
RUN	RUN	Start the AC drive in the operation panel control mode.
STOP/RES	Stop/Reset	Stop the AC drive when it is in the running state and perform the reset operation when it is in the fault state. The functions of this key are restricted in P7-02.
MF.K	Multifunction	Perform function switchover according to the setting of P7-01.
RVI	Keyboard potentiometer	Speed-control potentiometer

3 Function Code Tables

If PP-00 is set to a non-zero number, parameter protection is enabled. You must enter the correct user password to enter the menu.

To cancel the password protection function, enter with password and set PP-00 to 0.

Group P and Group E are standard function parameters. Group d is the monitoring function parameters.

The symbols in the function code table are described as follows:

"☆": The parameter can be modified when the AC drive is in either stop or running state. "

★": The parameter cannot be modified when the AC drive is in the running state.

"●": The parameter is the actually measured value and cannot be modified.

"*": The parameter is default parameter and can be set only by the manufacturer.

3.1 Standard Function Parameters

Table 3.1 Standard Function Parameters

Function Code	Parameter Name	Setting Range	Default	Property
Group P0: Standard Function Parameters				
P0-00	G/P type display	1: G type (constant torque load) 2: P type (variable torque load e.g. fan and pump)	Model dependent	•
P0-01	Motor control mode	0: Sensorless vector control (SVC) 1: Voltage/Frequency (V/F) control	1	★
P0-02	Command source selection	0: Operation panel control (LED off) 1: Terminal control (LED on) 2: Communication control (LED blinking)	0	☆
P0-03	Main frequency source X selection	0: Digital setting (preset frequency P0-08, UP/DOWN can be modified, non-retentive at power failure) 1: Digital setting (preset frequency P0-08, UP/DOWN can be modified, retentive at power failure) 2: AI1 3: AI2 4: Keyboard potentiometer 5: Pulse setting (DI5) 6: Multi-reference 7: Simple PLC 8: PID 9: Communication setting	4	★
P0-04	Auxiliary frequency source Y selection	The same as P0-03 (Main frequency source X selection)	0	★
P0-05	Range of auxiliary frequency Y for X and Y operation	0: Relative to maximum frequency 1: Relative to main frequency X	0	☆
P0-06	Range of auxiliary frequency Y for X and Y operation	0%-150%	100%	☆

Function Code	Parameter Name	Setting Range	Default	Property
P0-07	Frequency source selection	Unit's digit (Frequency source selection)	00	☆
		0: Main frequency source X 1: X and Y operation (operation relationship determined by ten's digit) 2: Switchover between X and Y 3: Switchover between X and "X and Y operation" 4: Switchover between Y and "X and Y operation"		
		Ten's digit (X and Y operation relationship)		
		0: X+Y 1: X-Y 2: Maximum 3: Minimum		
P0-08	Preset frequency	0.00 to maximum frequency (P0-10)	50.00Hz	☆
P0-09	Rotation direction	0: Same direction 1: Reverse direction	0	☆
P0-10	Maximum frequency	50.00-320.00 Hz	50.00 Hz	★
P0-11	Source of frequency upper limit	0: Set by P0-12 1: AI1 2: AI2 3: Keyboard potentiometer 4: Pulse setting 5: Communication setting	0	★
P0-12	Frequency upper limit	Frequency lower limit (P0-14) to maximum frequency (P0-10)	50.00 Hz	☆
P0-13	Frequency upper limit offset	0.00 Hz to maximum frequency (P0-10)	0.00 Hz	☆
P0-14	Frequency lower limit	0.00 Hz to frequency upper limit (P0-12)	0.00 Hz	☆
P0-15	Carrier frequency	0.5-16.0 kHz	Model dependent	☆
P0-16	Carrier frequency adjustment with temperature	0: No 1: Yes	1	☆
P0-17	Acceleration time 1	0.00-65000.00s	Model dependent	☆
P0-18	Deceleration time 1	0.00-65000.00s	Model dependent	☆

Function Code	Parameter Name	Setting Range	Default	Property
P0-19	Acceleration/Deceleration time unit	0:1s 1: 0.1s 2: 0.01s	1	★
P0-20	Reserved			
P0-21	Frequency offset of auxiliary frequency source for X and Y operation	0.00 Hz to maximum frequency (P0-10)	0.00 Hz	☆
P0-22	Frequency reference resolution	1: 0.1 Hz 2: 0.01 Hz	2	★
P0-23	Retentive of digital setting frequency upon power failure	0: Not retentive 1: Retentive	1	☆
P0-24	Reserved			
P0-25	Acceleration/Deceleration time base frequency	0: Maximum frequency(P0-10) 1: Set frequency 2: 100 Hz	0	★
P0-26	Base frequency for UP/ DOWN modification during running	0: Running frequency 1: Set frequency	0	★
P0-27	Binding command source to frequency source	Unit's digit (Binding operation panel command to frequency source)	000	☆
		0: No binding 1: Frequency source by digital setting 2: AI1 3: AI2 4: Keyboard potentiometer 5: Pulse setting(DI5) 6: Multi-reference 7: Simple PLC 8: PID 9: Communication setting		
		Ten's digit (Binding terminal command to frequency source)		
		Hundred's digit (Binding communication command to frequency source)		

Function Code	Parameter Name	Setting Range	Default	Property
Group P1: Motor Parameters				
P1-00	Motor type selection	0: Common asynchronous motor 1: Variable frequency asynchronous motor	0	★
P1-01	Rated motor power	0.1-1000.0 kW	Model dependent	★
P1-02	Rated motor voltage	1-2000 V	Model dependent	★
P1-03	Rated motor current	0.01-655.35 A (AC drive power ≤ 55 kW) 0.1-6553.5 A (AC drive power > 55 kW)	Model dependent	★
P1-04	Rated motor frequency	0.01 Hz to maximum frequency	Model dependent	★
P1-05	Rated motor rotational speed	1-65535 RPM	Model dependent	★
P1-06	Stator resistance (asynchronous motor)	0.001-65.535 Ω (AC drive power ≤ 55 kW) 0.0001-6.5535 Ω (AC drive power > 55 kW)	Tuned parameter	★
P1-07	Rotor resistance (asynchronous motor)	0.001-65.535 Ω (AC drive power ≤ 55 kW) 0.0001-6.5535 Ω (AC drive power > 55 kW)	Tuned parameter	★
P1-08	Leakage inductive reactance (asynchronous motor)	0.01-655.35mH (AC drive power ≤ 55 kW) 0.001-65.535mH (AC drive power > 55 kW)	Tuned parameter	★
P1-09	Mutual inductive reactance (asynchronous motor)	0.1-6553.5mH (AC drive power ≤ 55 kW) 0.01-655.35mH (AC drive power > 55 kW)	Tuned parameter	★
P1-10	No-load current (asynchronous motor)	0.01 to P1-03 (AC drive power ≤ 55 kW) 0.1 to P1-03 (AC drive power > 55 kW)	Tuned parameter	★
P1-11~P1-36	Reserved			
P1-37	Tuned selection	0: No operation 1: Motionless tune by asynchronous motor 2: Complete tune by asynchronous motor	0	★

Group P2: Vector Control Parameters				
Function Code	Parameter Name	Setting Range	Default	Property
P2-00	Speed loop proportional gain 1	0-100	30	☆
P2-01	Speed loop integral time 1	0.01-10.00s	0.50s	☆
P2-02	Switchover frequency 1	0.00 to P2-05	5.00Hz	☆
P2-03	Speed loop proportional gain 2	0-100	20	☆
P2-04	Speed loop integral time 2	0.01-10.00s	1.00s	☆
P2-05	Switchover frequency 2	P2-02 to maximum frequency	10.00Hz	☆
P2-06	Vector control slip gain	50%-200%	100%	☆
P2-07	Time constant of speed loop filter	0.000-0.100s	0.000s	☆
P2-08	Vector control over-excitation gain	0-200	64	☆
P2-09	Torque upper limit source in speed control mode	0: P2-10 1: AI1 2: AI2 3: Keyboard potentiometer 4: Pulse setting 5: Communication setting 6: MIN (AI1, AI2) 7: MAX (AI1, AI2)	0	☆
P2-10	Digital setting of torque upper limit in speed control mode	0.0%-200.0%	150.0%	☆
P2-11~P2-12	Reserved			
P2-13	Excitation adjustment proportional gain	0-60000	2000	☆
P2-14	Excitation adjustment integral gain	0-60000	1300	☆
P2-15	Torque adjustment proportional gain	0-60000	2000	☆
P2-16	Torque adjustment integral gain	0-60000	1300	☆
P2-17	Speed loop integral property	Unit's digit: integral separation 0: Disabled 1: Enabled	0	☆
P2-18~P2-22	Reserved			

Function Code	Parameter Name	Setting Range	Default	Property
Group P3: V/F Control Parameters				
P3-00	V/F curve setting	0: Linear V/F 1: Multi-point V/F 2: Square V/F 3: 1.2-power V/F 4: 1.4-power V/F 6: 1.6-power V/F 8: 1.8-power V/F 9: Reserved 10: V/F complete separation 11: V/F half separation	0	★
P3-01	Torque boost	0.0% (fixed torque boost) 0.1%-30.0%	Model dependent	☆
P3-02	Cut-off frequency of torque boost	0.00 Hz to maximum output frequency	50.00 Hz	★
P3-03	Multi-point V/F frequency 1 (F1)	0.00 Hz to P3-05	0.00 Hz	★
P3-04	Multi-point V/F voltage 1 (V1)	0.0%-100.0%	0.0%	★
P3-05	Multi-point V/F frequency 2 (F2)	P3-03 to P3-07	0.00 Hz	★
P3-06	Multi-point V/F voltage 2 (V2)	0.0%-100.0%	0.0%	★
P3-07	Multi-point V/F frequency 3 (F3)	P3-05 to rated motor frequency (P1-04)	0.00 Hz	★
P3-08	Multi-point V/F voltage 3 (V3)	0.0%-100.0%	0.0%	★
P3-09	V/F slip compensation gain	0%-200.0%	0.0%	☆
P3-10	V/F over-excitation gain	0-200	64	☆
P3-11	V/F oscillation suppression gain	0-100	Model dependent	☆
P3-12	Reserved			
P3-13	Voltage source for V/F separation	0: Digital setting (P3-14) 1: AI1 2: AI2 3: Keyboard potentiometer 4: Pulse setting (DI5) 5: Multi-reference 6: Simple PLC 7: PID 8: Communication setting Note: 100.0% corresponds to the rated motor voltage .	0	☆

Function Code	Parameter Name	Setting Range	Default	Property
P3-14	Voltage digital setting for V/F separation	0 V to rated motor voltage	0V	☆
P3-15	Voltage rise time of V/F separation	0.0-1000.0s It indicates the time for the voltage rising from 0 V to rated motor voltage.	0.0s	☆

Group P4: Input Terminals				
P4-00	DI1 function selection	0:No function 1:Forward RUN (FWD) 2:Reverse RUN (REV) 3:Three-line control 4:Forward JOG (FJOG) 5:Reverse JOG (RJOG) 6:Terminal UP 7:Terminal DOWN 8:Coast to stop 9:Fault reset (RESET) 10:RUN pause	1	★
P4-01	DI2 function selection	11:Normally open (NO) input of external fault 12:Multi-reference terminal 1 13:Multi-reference terminal 2 14:Multi-reference terminal 3 15:Multi-reference terminal 4 16:Terminal 1 for acceleration/ deceleration time selection 17:Terminal 2 for acceleration/ deceleration time selection 18:Frequency source switchover 19:UP and DOWN setting clear (terminal, operation panel) 20:Command source switchover terminal 1 21:Acceleration/Deceleration prohibited 22:PID pause	2	★
P4-02	DI3 function selection	23:PLC status reset 24:Swing pause 25:Counter input 26:Counter reset 27:Length count input 28:Length reset 29:Torque control prohibited 30:Pulse input (enabled only for DI5) 31:Reserved 32:Immediate DC braking	4	★
P4-03	DI4 function selection	33:Normally closed (NC) input of external fault 34:Frequency modificationForbidden 35:Reverse PID action direction 36:External STOP terminal 1 37:Command source switchover terminal 2 38:PID integral pause 39:Switchover between main frequency source X and preset frequency 40:Switchover between auxiliary frequency source Y and preset frequency	9	★
P4-04	DI5 function selection	41: Reserved 42: Reserved 43:PID parameter switchover 44:User-defined fault 1 45:User-defined fault 2 46:Speed control/Torque control switchover 47:Emergency stop 48:External STOP terminal 2 49:Deceleration DC braking 50:Clear the current running time 59: Reserved	0	★
P4-05~P4-09	Reserved		51-	

Function Code	Parameter Name	Setting Range	Default	Property
P4-10	DI filter time	0.000-1.000s	0.010s	☆
P4-11	Terminal command mode	0: Two-line mode 1 1: Two-line mode 2 2: Three-line mode 1 3: Three-line mode 2	0	★
P4-12	Terminal UP/DOWN rate	0.001-65.535Hz/s	1.00Hz/s	☆
P4-13	AI curve 1 minimum input	0.00 V to P4-15	0.00V	☆
P4-14	Corresponding setting of AI curve 1 minimum input	-100.00%-100.0%	0.0%	☆
P4-15	AI curve 1 maximum input	P4-13 to 10.00 V	10.00V	☆
P4-16	Corresponding setting of AI curve 1 maximum input	-100.00%-100.0%	100.0%	☆
P4-17	AI1 filter time	0.00-10.00s	0.10s	☆
P4-18	AI curve 2 minimum input	0.00 V to P4-20	0.00V	☆
P4-19	Corresponding setting of AI curve 2 minimum input	-100.00%-100.0%	0.0%	☆
P4-20	AI curve 2 maximum input	P4-18 to 10.00 V	10.00V	☆
P4-21	Corresponding setting of AI curve 2 maximum input	-100.00%-100.0%	100.0%	☆
P4-22	AI2 filter time	0.00-10.00s	0.10s	☆
P4-23~ P4-27	Reserved			
P4-28	Pulse minimum input	0.00 kHz to P4-30	0.00kHz	☆
P4-29	Corresponding setting of pulse minimum input	-100.00%-100.0%	0.0%	☆
P4-30	Pulse maximum input	P4-28 to 100.00 kHz	50.00kHz	☆
P4-31	Corresponding setting of pulse maximum input	-100.00%-100.0%	100.0%	☆
P4-32	Pulse filter time	0.00-10.00s	0.10s	☆

Function Code	Parameter Name	Setting Range	Default	Property
P4-33	AI curve selection	Unit's digit (AI1 curve selection)	321	☆
		1: Curve 1 (2 points, see P4-13 to P4-16) 2: Curve 2 (2 points, see P4-18 to P4-21) 3: Reserved 4: Curve 4 (4 points, see E6-00 to E6-07) 5: Curve 5 (4 points, see E6-08 to E6-15)		
		Ten's digit (AI2 curve selection)		
		Curve 1 to curve 5 (same as AI1)		
		Hundred's digit		
		Reserved		
P4-34	Setting for AI less than minimum input	Unit's digit (Setting for AI1 less than minimum input)	00	☆
		0: Minimum value 1: 0.0%		
		Ten's digit (Setting for AI2 less than minimum input)		
		0, 1 (same as AI1)		
P4-35	DI1 delay time	0.0-3600.0s	0.0s	★
P4-36	DI2 delay time	0.0-3600.0s	0.0s	★
P4-37	DI3 delay time	0.0-3600.0s	0.0s	★
P4-38	DI valid mode selection 1	0: High level valid 1: Low level valid	00000	★
		Unit's digit (DI1 valid mode)		
		Ten's digit (DI2 valid mode)		
		Hundred's digit (DI3 valid mode)		
		Thousand's digit (DI4 valid mode)		
		Ten thousand's digit (DI4 valid mode)		
P4-39	Reserved			

Function Code	Parameter Name	Setting Range	Default	Property
Group P5: Output Terminals				
P5-00	FM terminal output mode	0: Pulse output (FMP) 1: Switch signal output (FMR)	0	☆
P5-01	FMR function (open-collector output terminal)	0: No output 1: AC drive running 2: Fault output (stop) 3: Frequency-level detection PDT1 output	0	☆
P5-02	Relay function (T/A-T/B-T/C)	4: Frequency reached 5: Zero-speed running (no output at stop) 6: Motor overload pre-warning	2	☆
P5-03	Reserved	7: AC drive overload pre-warning 8: Set count value reached 9: Designated count value reached		
P5-04	DO1 function selection (open-collector output terminal)	11: PLC cycle complete 12: Accumulative running time reached 13: Frequency limited 14: Torque limited	1	☆
P5-05	Reserved	15: Ready for RUN 16: AI1 larger than AI2 17: Frequency upper limit reached 18: Frequency lower limit reached (no output at stop) 19: Undervoltage state output 20: Communication setting 23: Zero-speed running 2 (having output at stop) 24: Accumulative power-on time reached 25: Frequency level detection PDT2 output 26: Frequency 1 reached 27: Frequency 2 reached 28: Current 1 reached 29: Current 2 reached 30: Timing reached 31: AI1 input limit exceeded 32: Load becoming 0 33: Reverse running 34: Zero current state 35: Module temperature reached 36: Software current limit exceeded 37: Frequency lower limit reached (having output at stop) 38: Alarm output 39: Reserved 40: Current running time reached 41: Fault output (There is no output if it is the coast to stop Fault and undervoltage occurs.)		

Function Code	Parameter Name	Setting Range	Default	Property
P5-06	FMP function selection	0: Running frequency 1: Set frequency 2: Output current 3: Output torque (absolute value) 4: Output power 5: Output voltage 6: Pulse input (100% corresponds 100.0kHz) 7: AI1	0	☆
P5-07	AO1 function selection	8: AI2 9 Keyboard potentiometer 10: length 11: Count value 12: Communication setting 13: Motor rotational speed 14: Output current (100% corresponds 1000.0A) 15: Output voltage (100% corresponds 1000.0V) 16: Reserved	0	☆
P5-08	Reserved			
P5-09	Maximum FMP output frequency	0.01-100.00 kHz	50.00kHz	☆
P5-10	AO1 offset coefficient	-100.0%-100.0%	0.0%	☆
P5-11	AO1 gain	-10.00-10.00	1.00	☆
P5-12~P5-16	Reserved			
P5-17	FMR output delay time	0.0-3600.0s	0.0s	☆
P5-18	Relay 1 output close delay time	0.0-3600.0s	0.0s	☆
P5-19	Reserved			
P5-20	DO1 output delay time	0.0-3600.0s	0.0s	☆
P5-21	Reserved			
P5-22	DO valid mode selection	Unit's digit (FMR valid mode) 0: Positive logic 1: Negative logic Ten's digit (Relay 1 valid mode) 0, 1 (same as FMR) Thousand's digit (DO1 valid mode) 0, 1 (same as FMR)	00000	☆
Group P6: Start/Stop Control				
P6-00	Start mode	0: Direct start 1: Rotational speed tracking restart 2: Pre-excited start (asynchronous motor)	0	☆
P6-01	Rotational speed tracking mode	0: From frequency at stop 1: From zero speed 2: From maximum frequency	0	★

Function Code	Parameter Name	Setting Range	Default	Property
P6-02	Rotational speed tracking speed	1-100	20	☆
P6-03	Startup frequency	0.00 ~10.00Hz	0.00 Hz	☆
P6-04	Startup frequency holding time	0.0 ~ 100.0s	0.0s	★
P6-05	Startup DC braking current/ Pre-excited current	0%-100%	0%	★
P6-06	Startup DC braking time/ Pre-excited time	0.0-100.0s	0.0s	★
P6-07	Acceleration/Deceleration mode	0: Linear acceleration/ deceleration 1: S-curve acceleration/ deceleration A 2: S-curve acceleration/ deceleration B	0	★
P6-08	Time proportion of S-curve start segment	0.0% to (100.0% - P6-09)	30.0%	★
P6-09	Time proportion of S-curve end segment	0.0% to (100.0% - P6-08)	30.0%	★
P6-10	Stop mode	0: Decelerate to stop 1: Coast to stop	0	☆
P6-11	Initial frequency of stop DC braking	0.00 Hz to maximum frequency	0.00 Hz	☆
P6-12	Waiting time of stop DC braking	0.0-100.0s	0.0s	☆
P6-13	Stop DC braking current	0%-100%	0%	☆
P6-14	Stop DC braking time	0.0-100.0s	0.0s	☆
P6-15	Brake use ratio	0%-100%	100%	☆
Group P7: Operation Panel and Display				
P7-01	MF.K Key function selection	0: MF.K key disabled 1: Switchover between operation panel control and remote command control (terminal or communication) 2: Switchover between forward rotation and reverse rotation 3: Forward JOG 4: Reverse JOG	3	★
P7-02	STOP/RESET key function	0: STOP/RESET key enabled only in operation panel control 1: STOP/RESET key enabled in any operation mode	1	☆

Function Code	Parameter Name	Setting Range	Default	Property
P7-03	LED display running parameters 1	0000-FFFF Bit00: Running frequency (Hz) Bit01: Set frequency (Hz) Bit02: Bus voltage (V) Bit03: Output voltage (V) Bit04: Output current (A) Bit05: Output power (kW) Bit06: Output torque (%) Bit07: DI input status Bit08: DO output status Bit09: AI1 voltage (V) Bit10: AI2 voltage (V) Bit12: Count value Bit13: Length value Bit14: Load speed display Bit15: PID setting	001F	☆
P7-04	LED display running parameters 2	0000-FFFF Bit00: PID feedback Bit01: PLC stage Bit02: Pulse setting frequency (kHz) Bit03: Running frequency 2 (Hz) Bit04: Remaining running time Bit05: AI1 voltage before correction (V) Bit06: AI2 voltage before correction (V) Bit08: Linear speed Bit09: Current power-on time (Hour) Bit10: Current running time (Min) Bit11: Pulse setting frequency (Hz) Bit12: Communication setting value Bit14: Main frequency X display (Hz) Bit15: Auxiliary frequency Y display (Hz)	0000	☆
P7-05	LED display stop parameters	0000-FFFF Bit00: Set frequency (Hz) Bit01: Bus voltage (V) Bit02: DI input status Bit03: DO output status Bit04: AI1 voltage (V) Bit05: AI2 voltage (V) Bit07: Count value Bit08: Length value Bit09: PLC stage Bit10: Load speed Bit11: PID setting Bit12: Pulse setting frequency(kHz)	0033	☆
P7-06	Load speed display coefficient	0.0001-6.5000	1.0000	☆
P7-07	Heatsink temperature of inverter module	0.0-100.0°C	-	●
P7-08	Passwords for timing stop	0-65535 (Please remember the password to apply the function)	-	●

Function Code	Parameter Name	Setting Range	Default	Property
P7-09	Accumulative running time	0-65535h	-	●
P7-10	Preset value for timing stop	0-65535h	0	●
P7-11	Reserved			
P7-12	Number of decimal places for load speed display	0: 0 decimal places 1: 1 decimal places 2: 2 decimal places 3: 3 decimal places	1	☆
P7-13	Accumulative power-on time	0-65535 h	-	●
P7-14	Accumulative power consumption	0-65535 kWh	-	●
Group P8: Auxiliary Functions				
P8-00	JOG running frequency	0.00 Hz to maximum frequency	5.00 Hz	☆
P8-01	JOG acceleration time	0.0-6500.0s	20.0s	☆
P8-02	JOG deceleration time	0.0-6500.0s	20.0s	☆
P8-03	Acceleration time 2	0.0-6500.0s	Model dependent	☆
P8-04	Deceleration time 2	0.0-6500.0s	Model dependent	☆
P8-05	Acceleration time 3	0.0-6500.0s	Model dependent	☆
P8-06	Deceleration time 3	0.0-6500.0s	Model dependent	☆
P8-07	Acceleration time 4	0.0-6500.0s	Model dependent	☆
P8-08	Deceleration time 4	0.0-6500.0s	Model dependent	☆
P8-09	Jump frequency 1	0.00 Hz to maximum frequency	0.00 Hz	☆
P8-10	Jump frequency 2	0.00 Hz to maximum frequency	0.00 Hz	☆
P8-11	Frequency jump amplitude	0.00 Hz to maximum frequency	0.00 Hz	☆
P8-12	Forward/Reverse rotation dead-zone time	0.0-3000.0s	0.0s	~
P8-13	Reverse control	0: Enabled 1: Disabled	0	~
P8-14	Running mode when set frequency lower than frequency lower limit	0: Run at frequency lower limit 1: Stop 2: Run at zero speed	0	☆
P8-15	Droop control	0.00-10.00 Hz	0.00 Hz	☆
P8-16	Accumulative power-on time threshold	0-65000 h	0 h	☆

Function Code	Parameter Name	Setting Range	Default	Property
P8-17	Accumulative running time threshold	0-65000 h	0 h	☆
P8-18	Startup protection	0: No 1: Yes	0	☆
P8-19	Frequency detection value (PDT1)	0.00 Hz to maximum frequency	50.00 Hz	☆
P8-20	Frequency detection hysteresis (PDT hysteresis 1)	0.0%-100.0% (PDT1 level)	5.0%	☆
P8-21	Detection range of frequency reached	0.00-100% (maximum frequency)	0.0%	☆
P8-22	Jump frequency during acceleration/ deceleration	0: Disabled 1: Enabled	0	☆
P8-23	Reserved			
P8-25	Frequency switchover point between acceleration time 1 and acceleration time 2	0.00 Hz to maximum frequency	0.00 Hz	☆
P8-26	Frequency switchover point between deceleration time 1 and deceleration time 2	0.00 to maximum frequency	0.00 Hz	☆
P8-27	Terminal JOG preferred	0: Disabled 1: Enabled	0	☆
P8-28	Frequency detection value (PDT2)	0.00 to maximum frequency	50.00 Hz	☆
P8-29	Frequency detection hysteresis (PDT hysteresis 2)	0.0%-100.0% (PDT2 level)	5.0%	☆
P8-30	Any frequency reaching detection value 1	0.00 Hz to maximum frequency	50.00 Hz	☆
P8-31	Any frequency reaching detection amplitude 1	0.0%-100.0% (maximum frequency)	0.0%	☆
P8-32	Any frequency reaching detection value 2	0.00 Hz to maximum frequency	50.00 Hz	☆
P8-33	Any frequency reaching detection amplitude 2	0.0%-100.0% (maximum frequency)	0.0%	☆
P8-34	Zero current detection level	0.0%-300.0% (rated motor current)	5.0%	☆
P8-35	Zero current detection delay time	0.01-600.00s	0.10s	☆
P8-36	Output overcurrent threshold	1. 0% (no detection) 2. 0.1%-300.0% (rated motor current)	200.0%	☆
P8-37	Output overcurrent detection delay time	0.00-600.00s	0.00s	☆

Function Code	Parameter Name	Setting Range	Default	Property
P8-38	Any current reaching 1	0.0%-300.0% (rated motor current)	100.0%	☆
P8-39	Any current reaching 1 amplitude	0.0%-300.0% (rated motor current)	0.0%	☆
P8-40	Any current reaching 2	0.0%-300.0% (rated motor current)	100.0%	☆
P8-41	Any current reaching 2 amplitude	0.0%-300.0% (rated motor current)	0.0%	☆
P8-42	Timing function	0: Disabled 1: Enabled	0	☆
P8-43	Timing duration source	0: P8-44 1: AI1 2: AI2 3: Keyboard potentiometer (100% of analog input corresponds to the value of P8-44)	0	☆
P8-44	Timing duration	0.0-6500.0 min	0.0 min	☆
P8-45	AI1 input voltage lower limit	0.00 V to P8-46	3.10 V	☆
P8-46	AI1 input voltage upper limit	P8-45 to 10.00 V	6.80 V	☆
P8-47	Module temperature threshold	0-100°C	75°C	☆
P8-48	Cooling fan control	0: Fan working during running 1: Fan working continuously	0	☆
P8-49	Wakeup frequency	Dormant frequency (P8-51) to maximum frequency (P0-10)	0.00 Hz	☆
P8-50	Wakeup delay time	0.0-6500.0s	0.0s	☆
P8-51	Dormant frequency	0.00 Hz to wakeup frequency (P8-49)	0.00 Hz	☆
P8-52	Dormant delay time	0.0-6500.0s	0.0s	☆
P8-53	Current running time reached	0.0-6500.0 min	0.0 min	☆
Group P9: Fault and Protection				
P9-00	Motor overload protection selection	0: Disabled 1: Enabled	1	☆
P9-01	Motor overload protection gain	0.20-10.00	1.00	☆
P9-02	Motor overload warning coefficient	50%-100%	80%	☆

Function Code	Parameter Name	Setting Range	Default	Property
P9-03	Overvoltage stall gain	0 (no stall overvoltage)-100	0	☆
P9-04	Overvoltage stall protective voltage	120%-150%	130%	☆
P9-05	Overcurrent stall gain	0-100	20	☆
P9-06	Overcurrent stall protective current	100%-200%	150%	☆
P9-07	Short-circuit to ground upon power-on	0: Disabled 1: Enabled	1	☆
P9-08	Reserved			
P9-09	Fault auto reset times	0-20	0	☆
P9-10	DO action during fault auto reset	0: Not act 1: Act	0	☆
P9-11	Time interval of fault auto reset	0.1s-100.0s	1.0s	☆
P9-12	Input phase loss protection/ contactor energizing protection selection	Unit's digit: Input phase loss protection Ten's digit: Contactor energizing Protection 0: Disabled 1: Enabled	11	☆
P9-13	Output phase loss protection selection	0: Disabled 1: Enabled	1	☆

Function Code	Parameter Name	Setting Range	Default	Property
P9-14	1st fault type	0: No fault 1: Reserved 2: Overcurrent during acceleration 3: Overcurrent during deceleration 4: Overcurrent at constant speed 5: Overvoltage during acceleration 6: Overvoltage during deceleration 7: Overvoltage at constant speed 8: Buffer resistance overload 9: Undervoltage 10: AC drive overload 11: Motor overload 12: Power input phase loss	-	●
P9-15	2nd fault type	13: Power output phase loss 14: Module overheat 15: External equipment fault 16: Communication fault 17: Contactor fault 18: Current detection fault 19: Motor auto-tuning fault 20: Reserved 21: EEPROM read-write fault 22: AC drive hardware fault 23: Short circuit to ground 24: Reserved 25: Reserved	-	●
P9-16	3rd (latest) fault type	26: Accumulative running time reached 27: User-defined fault 1 28: User-defined fault 2 29: Accumulative power-on time reached 30: Load becoming 0 31: PID feedback lost during running 40: With-wave current limit fault 41~51: Reserved	-	●
P9-17	Frequency upon 3rd fault	-	-	●
P9-18	Current upon 3rd fault	-	-	●
P9-19	Bus voltage upon 3rd fault	-	-	●
P9-20	DI status upon 3rd fault	-	-	●
P9-21	Output terminal status upon 3rd fault	-	-	●
P9-22	AC drive status upon 3rd fault	-	-	●

Function Code	Parameter Name	Setting Range	Default	Property
P9-23	Power-on time upon 3rd fault	-	-	●
P9-24	Running time upon 3rd fault	-	-	●
P9-25	Reserved			
P9-27	Frequency upon 2nd fault	-	-	●
P9-28	Current upon 2nd fault	-	-	●
P9-29	Bus voltage upon 2nd fault	-	-	●
P9-30	DI status upon 2nd fault	-	-	●
P9-31	Output terminal status upon 2nd fault	-	-	●
P9-32	AC drive status upon 2nd fault	-	-	●
P9-33	Power-on time upon 2nd Fault	-	-	●
P9-34	Running time upon 2nd Fault	-	-	●
P9-35	Reserved			
P9-37	Frequency upon 1st Fault	-	-	●
P9-38	Current upon 1st Fault	-	-	●
P9-39	Bus voltage upon 1st Fault	-	-	●
P9-40	DI status upon 1st Fault	-	-	●
P9-41	Output terminal status upon 1st Fault	-	-	●
P9-42	AC drive status upon 1st Fault	-	-	●
P9-43	Power-on time upon 1st Fault	-	-	●
P9-44	Running time upon 1st Fault	-	-	●
P9-45	Reserved			

Function Code	Parameter Name	Setting Range	Default	Property
P9-47	Fault protection action selection 1	Unit's digit (Motor overload, Err11)	00000	☆
		0: Coast to stop 1: Stop according to the stop mode 2: Continue to run		
		Ten's digit (Power input phase loss, Err12)		
		Hundred's digit (Power output phase loss, Err13)		
		Thousand's digit (External equipment Fault, Err15)		
		Ten thousand's digit (Communication Fault, Err16)		
P9-48	Reserved			
P9-49	Fault protection action selection 3	Unit's digit (User-defined fault 1,Err27)	00000	☆
		Same as unit's digit in P9-47		
		Ten's digit (User-defined fault 2,Err28)		
		Same as unit's digit in P9-47		
		Hundred's digit (Accumulative power-on time reached, Err29)		
		Same as unit's digit in P9-47		
		Thousand's digit (Load becoming 0, Err30)		
		0: Coast to stop 1: Stop according to the stop mode 2: Continue to run at 7% of rated motor frequency and resume		
		Ten thousand's digit (PID feedback lost during running,Err31)		
		Same as unit's digit in P9-47		
P9-50~P9-53	Reserved			
P9-54	Frequency selection for continuing to run upon Fault	0: Current running frequency 1: Set frequency 2: Frequency upper limit 3: Frequency lower limit 4: Backup frequency upon abnormality	0	☆
P9-55	Backup frequency upon abnormality	0.0%-100.0% (maximum frequency)	100.0%	☆
P9-56~P9-58	Reserved			
P9-59	Action selection at instantaneous power Failure	0: Invalid 1: Decelerate 2: Decelerate to stop	0	☆

Function Code	Parameter Name	Setting Range	Default	Property
P9-60	Action pause judging voltage at instantaneous power Failure	80.0%-100.0%	90.0%	☆
P9-61	Voltage rally judging time at instantaneous power Failure	0.00-100.00s	0.50s	☆
P9-62	Action judging voltage at instantaneous power Failure	60.0%-100.0% (standard bus voltage)	80.0%	☆
P9-63	Protection upon load becoming 0	0: Disabled 1: Enabled	0	☆
P9-64	Detection level of load becoming 0	0.0%-100.0%	10.0%	☆
P9-65	Detection time of load becoming 0	0.0-60.0s	1.0s	☆
P9-66	Reserved			
Group PA: PID Function				
PA-00	PID setting source	0: PA-01 1: AI1 2: AI2 3: Keyboard potentiometer 4: Pulse setting (DI5) 5: Communication setting 6: Multi-reference	0	☆
PA-01	PID digital setting	0.0%-100.0%	50.0%	☆
PA-02	PID feedback source	0: AI1 1: AI2 2: Keyboard potentiometer 3: AI1 - AI2 4: Pulse setting (DI5) 5: Communication setting 6: AI1 + AI2 7: MAX (AI1 , AI2) 8: MIN (AI1 , AI2)	0	☆
PA-03	PID action direction	0: Forward action 1: Reverse action	0	☆
PA-04	PID setting feedback range	0-65535	1000	☆
PA-05	Proportional gain Kp1	0.0-100.0	20.0	☆
PA-06	Integral time Ti1	0.01-10.00s	2.00s	☆
PA-07	Differential time Td1	0.000-10.000s	0.000s	☆
PA-08	Cut-off frequency of PID reverse rotation	0.00 to maximum frequency	2.00Hz	☆

Function Code	Parameter Name	Setting Range	Default	Property
PA-09	PID deviation limit	0.0%-100.0%	0.0%	☆
PA-10	PID differential limit	0.00%-100.00%	0.10%	☆
PA-11	PID setting change time	0.00-650.00s	0.00s	☆
PA-12	PID feedback filter time	0.00-60.00s	0.00s	☆
PA-13	PID output filter time	0.00-60.00s	0.00s	☆
PA-14	Reserved			
PA-15	Proportional gain Kp2	0.0-100.0	20.0	☆
PA-16	Integral time Ti2	0.01-10.00s	2.00s	☆
PA-17	Differential time Td2	0.000-10.000s	0.000s	☆
PA-18	PID parameter switchover condition	0: No switchover 1: Switchover via DI 2: Automatic switchover based on deviation	0	☆
PA-19	PID parameter switchover deviation 1	0.0% to PA-20	20.0%	☆
PA-20	PID parameter switchover deviation 2	PA-19 to 100.0%	80.0%	☆
PA-21	PID initial value	0.0%-100.0%	0.0%	☆
PA-22	PID initial value holding time	0.00-650.00s	0.00s	☆
PA-23	Maximum deviation between two PID outputs in forward direction	0.00%-100.00%	1.00%	☆
PA-24	Maximum deviation between two PID outputs in reverse direction	0.00%-100.00%	1.00%	☆
PA-25	PID integral property	Unit's digit (Integral separated)	00	☆
		0: Invalid 1: Valid		
		Ten's digit (Whether to stop integral operation when the output reaches the limit)		
		0: Continue integral operation 1: Stop integral operation		
PA-26	Detection value of PID feedback loss	0.0%: Not judging feedback loss 0.1%-100.0%	0.0%	☆

Function Code	Parameter Name	Setting Range	Default	Property
PA-27	Detection time of PID feedback loss	0.0-20.0s	0.0s	☆
PA-28	PID operation at stop	0: No PID operation at stop 1: PID operation at stop	0	☆
Group Pb: Swing Frequency, Fixed Length and Count				
Pb-00	Swing frequency setting mode	0: Relative to the central frequency 1: Relative to the maximum frequency	0	☆
Pb-01	Swing frequency amplitude	0.0%-100.0%	0.0%	☆
Pb-02	Jump frequency amplitude	0.0%-50.0%	0.0%	☆
Pb-03	Swing frequency cycle	0.0-3000.0s	10.0s	☆
Pb-04	Triangular wave rising time coefficient	0.0%-100.0%	50.0%	☆
Pb-05	Set length	0-65535 m	1000m	☆
Pb-06	Actual length	0-65535 m	0m	☆
Pb-07	Number of pulses per meter	0.1-6553.5	100.0	☆
Pb-08	Set count value	1-65535	1000	☆
Pb-09	Designated count value	1-65535	1000	☆
Group PC: Multi-Reference and Simple PLC Function				
PC-00	Reference 0	-100.0%-100.0%	0.0%	☆
PC-01	Reference 1	-100.0%-100.0%	0.0%	☆
PC-02	Reference 2	-100.0%-100.0%	0.0%	☆
PC-03	Reference 3	-100.0%-100.0%	0.0%	☆
PC-04	Reference 4	-100.0%-100.0%	0.0%	☆
PC-05	Reference 5	-100.0%-100.0%	0.0%	☆
PC-06	Reference 6	-100.0%-100.0%	0.0%	☆
PC-07	Reference 7	-100.0%-100.0%	0.0%	☆
PC-08	Reference 8	-100.0%-100.0%	0.0%	☆
PC-09	Reference 9	-100.0%-100.0%	0.0%	☆
PC-10	Reference 10	-100.0%-100.0%	0.0%	☆

Function Code	Parameter Name	Setting Range	Default	Property
PC-11	Reference 11	-100.0%-100.0%	0.0%	☆
PC-12	Reference 12	-100.0%-100.0%	0.0%	☆
PC-13	Reference 13	-100.0%-100.0%	0.0%	☆
PC-14	Reference 14	-100.0%-100.0%	0.0%	☆
PC-15	Reference 15	-100.0%-100.0%	0.0%	☆
PC-16	Simple PLC running mode	0: Stop after the AC drive runs one cycle 1: Keep final values after the AC drive runs one cycle 2: Repeat after the AC drive runs one cycle	0	☆
PC-17	Simple PLC retentive selection	Unit's digit (Retentive upon power Failure)	00	☆
		0: No 1: Yes		
		Ten's digit (Retentive upon stop)		
		0: No 1: Yes		
PC-18	Running time of simple PLC reference 0	0.0-6553.5s (h)	0.0s(h)	☆
PC-19	Acceleration/deceleration time of simple PLC reference 0	0-3	0	☆
PC-20	Running time of simple PLC reference 1	0.0-6553.5s (h)	0.0s(h)	☆
PC-21	Acceleration/deceleration time of simple PLC reference 1	0-3	0	☆
PC-22	Running time of simple PLC reference 2	0.0-6553.5s (h)	0.0s (h)	☆
PC-23	Acceleration/deceleration time of simple PLC reference 2	0-3	0	☆
PC-24	Running time of simple PLC reference 3	0.0-6553.5s (h)	0.0s(h)	☆
PC-25	Acceleration/deceleration time of simple PLC reference 3	0-3	0	☆
PC-26	Running time of simple PLC reference 4	0.0-6553.5s (h)	0.0s(h)	☆
PC-27	Acceleration/deceleration time of simple PLC reference 4	0-3	0	☆

Function Code	Parameter Name	Setting Range	Default	Property
PC-28	Running time of simple PLC reference 5	0.0-6553.5s (h)	0.0s(h)	☆
PC-29	Acceleration/deceleration time of simple PLC reference 5	0-3	0	☆
PC-30	Running time of simple PLC reference 6	0.0-6553.5s (h)	0.0s(h)	☆
PC-31	Acceleration/deceleration time of simple PLC reference 6	0-3	0	☆
PC-32	Running time of simple PLC reference 7	0.0-6553.5s (h)	0.0s(h)	☆
PC-33	Acceleration/deceleration time of simple PLC reference 7	0-3	0	☆
PC-34	Running time of simple PLC reference 8	0.0-6553.5s (h)	0.0s(h)	☆
PC-35	Acceleration/deceleration time of simple PLC reference 8	0-3	0	☆
PC-36	Running time of simple PLC reference 9	0.0-6553.5s (h)	0.0s(h)	☆
PC-37	Acceleration/deceleration time of simple PLC reference 9	0-3	0	☆
PC-38	Running time of simple PLC reference 10	0.0-6553.5s (h)	0.0s(h)	☆
PC-39	Acceleration/deceleration time of simple PLC reference 10	0-3	0	☆
PC-40	Running time of simple PLC reference 11	0.0-6553.5s (h)	0.0s(h)	☆
PC-41	Acceleration/deceleration time of simple PLC reference 11	0-3	0	☆
PC-42	Running time of simple PLC reference 12	0.0-6553.5s (h)	0.0s(h)	☆
PC-43	Acceleration/deceleration time of simple PLC reference 12	0-3	0	☆
PC-44	Running time of simple PLC reference 13	0.0-6553.5s (h)	0.0s(h)	☆
PC-45	Acceleration/deceleration time of simple PLC reference 13	0-3	0	☆
PC-46	Running time of simple PLC reference 14	0.0-6553.5s (h)	0.0s(h)	☆

Function Code	Parameter Name	Setting Range	Default	Property
PC-47	Acceleration/deceleration time of simple PLC reference 14	0-3	0	☆
PC-48	Running time of simple PLC reference 15	0.0-6553.5s (h)	0.0s(h)	☆
PC-49	Acceleration/deceleration time of simple PLC reference 15	0-3	0	☆
PC-50	Time unit of simple PLC running	0: s (second) 1:h (hour)	0	☆
PC-51	Reference 0 source	0: Set by PC-00 1: AI1 2: AI2 3: Keyboard potentiometer 4: Pulse setting 5: PID 6: Set by preset frequency (P0- 08), modified via terminal UP/ DOWN	0	☆
Group Pd: Communication Parameters				
Pd-00	Baud rate	0: 300 BPs 1: 600 BPs 2: 1200 BPs 3: 2400 BPs 4: 4800 BPs 5: 9600 BPs 6: 19200 BPs 7: 38400 BPs 8: 57600 BPs 9: 115200 BPs	5	☆
Pd-01	Data format	0: No check, data format <8,N,2> 1: Even parity check, data format <8,E,1> 2: Odd Parity check, data format <8,O,1> 3: No check, data format <8,N,1> Valid for Modbus	0	☆
Pd-02	Local address	0: Broadcast address 1-249	1	☆
Pd-03	Response delay	0-20 ms	2 ms	☆
Pd-04	Communication timeout	0.0s (invalid) 0.1-60.0s	0.0s	☆
Pd-05	Modbus protocol selection	0: Non-standard Modbus protocol 1: Standard Modbus protocol	0	☆
Pd-06	Communication reading current resolution	0: 0.01A 1: 0.1A	0	☆

Function Code	Parameter Name	Setting Range	Default	Property
Pd-07	Master and slave selection	0: master 1: slave	0	☆
Group PP: Function Code Management				
PP-00	User password	0-65535	0	☆
PP-01	Restore default settings	0: No operation 01: Restore factory settings except motor parameters 02: Clear records	0	★
PP-02	AC drive parameter display property	Unit's digit (Group d display selection)	11	★
		0: Not display 1: Display		
		Ten's digit (Group E display selection)		
		0: Not display		
PP-03	Reserved			
PP-04	Parameter modification property	0: Modifiable 1: Not modifiable	0	☆
Group E0: Torque Control and Restricting Parameters				
E0-00	Speed/Torque control selection	0: Speed control 1: Torque control	0	★
E0-01	Torque setting source in torque control	0: Digital setting (E0-03) 1: AI1 2: AI2 3: Keyboard potentiometer 4: Pulse setting (DI5) 5: Communication setting 6: MIN (AI1, AI2) 7: MAX (AI1, AI2) Full range of values 1-7 corresponds to the digital setting of E0-03.	0	★
E0-02	Reserved			
E0-03	Torque digital setting in torque control	-200.0%-200.0%	150.0%	☆
E0-05	Forward maximum frequency in torque control	0.00 Hz to maximum frequency	50.00Hz	☆
E0-06	Reverse maximum frequency in torque control	0.00 Hz to maximum frequency	50.00Hz	☆
E0-07	Acceleration time in torque control	0.00-65000s	0.00s	☆
E0-08	Deceleration time in torque control	0.00-65000s	0.00s	☆

Function Code	Parameter Name	Setting Range	Default	Property
Group E5: Control Optimization Parameters				
E5-00	DPWM switchover frequency upper limit	0.00-15.00 Hz	12.00Hz	☆
E5-01	PWM modulation mode	0: Asynchronous modulation 1: Synchronous modulation	0	☆
E5-02	Dead zone compensation mode selection	0: No compensation 1: Compensation mode 1 2: Compensation mode 2	1	☆
E5-03	Random PWM depth	0: Random PWM invalid 1-10: Random depth of PMW carrier frequency	0	☆
E5-04	Rapid current limit	0: Disabled 1: Enabled	1	☆
E5-05	Current detection compensation	0-100	5	☆
E5-06	Undervoltage threshold	60.0%-140.0%	100.0%	☆
E5-07	SVC optimization mode selection	0: No optimization 1: Optimization mode 1 2: Optimization mode 2	1	☆
E5-08	Dead-zone time adjustment	100%-200%	150%	☆
E5-09	Overvoltage threshold	200.0-2500.0 V	Model depend	☆
Group E6: AI Curve Setting				
E6-00	AI curve 4 minimum input	-10.00 V to E6-02	0.00V	☆
E6-01	Corresponding setting of AI curve 4 minimum input	-100.0%-100.0%	0.0%	☆
E6-02	AI curve 4 inflexion 1 input	E6-00 to E6-04	3.00V	☆
E6-03	Corresponding setting of AI curve 4 inflexion 1 input	-100.0%-100.0%	30.0%	☆
E6-04	AI curve 4 inflexion 2 input	E6-02 to E6-06	6.00V	☆
E6-05	Corresponding setting of AI curve 4 inflexion 2 input	-100.0%-100.0%	60.0%	☆
E6-06	AI curve 4 maximum input	E6-06 to 10.00 V	10.00V	☆
E6-07	Corresponding setting of AI curve 4 maximum input	-100.0%-100.0%	100.0%	☆
E6-08	AI curve 5 minimum input	-10.00 V to E6-10	-10.00V	☆
E6-09	Corresponding setting of AI curve 5 minimum input	-100.0%-100.0%	-100.0%	☆
E6-10	AI curve 5 inflexion 1 input	E6-08 to E6-12	-3.00V	☆

Function Code	Parameter Name	Setting Range	Default	Property
E6-11	Corresponding setting of AI curve 5 inflexion 1 input	-100.0%-100.0%	-30.0%	☆
E6-12	AI curve 5 inflexion 2 input	E6-10 to E6-14	3.00V	☆
E6-13	Corresponding setting of AI curve 5 inflexion 2 input	-100.0%-100.0%	30.0%	☆
E6-14	AI curve 5 maximum input	E6-12 to 10.00 V	10.00V	☆
E6-15	Corresponding setting of AI curve 5 maximum input	-100.0%-100.0%	100.0%	☆
E6-16~E6-23	Reserved			
E6-24	Jump point of AI1 input corresponding setting	-100.0%-100.0%	0.0%	☆
E6-25	Jump amplitude of AI1 input corresponding setting	0.0%-100.0%	0.5%	☆
E6-26	Jump point of AI2 input corresponding setting	-100.0%-100.0%	0.0%	☆
E6-27	Jump amplitude of AI2 input corresponding setting	0.0%-100.0%	0.5%	☆
E6-28~E6-29	Reserved			
Group EC: AI/AO Correction				
EC-00	AI1 measured voltage 1	0.500-4.000 V	Factory corrected	☆
EC-01	AI1 displayed voltage 1	0.500-4.000 V	Factory corrected	☆
EC-02	AI1 measured voltage 2	6.000-9.999 V	Factory corrected	☆
EC-03	AI1 displayed voltage 2	6.000-9.999 V	Factory corrected	☆
EC-04	AI2 measured voltage 1	0.500-4.000 V	Factory corrected	☆
EC-05	AI2 displayed voltage 1	0.500-4.000 V	Factory corrected	☆
EC-06	AI2 measured voltage 2	6.000-9.999 V	Factory corrected	☆
EC-07	AI2 displayed voltage 2	6.000-9.999 V	Factory corrected	☆
EC-08~EC-11	Reserved			
EC-12	AO1 target voltage 1	0.500-4.000 V	Factory corrected	☆
EC-13	AO1 measured voltage 1	0.500-4.000 V	Factory corrected	☆
EC-14	AO1 target voltage 2	6.000-9.999 V	Factory corrected	☆

Function Code	Parameter Name	Setting Range	Default	Property
EC-15	AO1 measured voltage 2	6.000-9.999 V	Factory corrected	☆
EC-16~EC-19	Reserved			

3.2 Monitoring Parameters

Table 3.2 Monitoring Parameter Table

Function Code	Parameter Name	Min. Unit	Communication Address
Group d0: Standard Monitoring Parameters			
d0-00	Running frequency (Hz)	0.01 Hz	7000H
d0-01	Set frequency (Hz)	0.01 Hz	7001H
d0-02	Bus voltage	0.1 V	7002H
d0-03	Output voltage	1 V	7003H
d0-04	Output current	0.01 A	7004H
d0-05	Output power	0.1 kW	7005H
d0-06	Output torque (%)	0.1%	7006H
d0-07	DI state	1	7007H
d0-08	DO state	1	7008H
d0-09	AI1 voltage (V)	0.01 V	7009H
d0-10	AI2 voltage (V)	0.01 V	700AH
d0-12	Count value	1	700CH
d0-13	Length value	1	700DH
d0-14	Load speed	1	700EH
d0-15	PID setting	1	700FH
d0-16	PID feedback	1	7010H
d0-17	PLC stage	1	7011H

Function Code	Parameter Name	Min. Unit	Communication Address
d0-18	Input pulse frequency (Hz)	0.01 kHz	7012H
d0-19	Feedback speed (0.1Hz)	0.1 Hz	7013H
d0-20	Remaining running time	0.1 Min	7014H
d0-21	AI1 voltage before correction	0.001 V	7015H
d0-22	AI2 voltage (V) before correction	0.001 V	7016H
d0-24	Linear speed	1 m/Min	7018H
d0-25	Accumulative power-on time	1 Min	7019H
d0-26	Accumulative running time	0.1 Min	701AH
d0-27	Pulse input frequency	1 Hz	701BH
d0-28	Communication setting value	0.01%	701CH
d0-30	Main frequency X	0.01 Hz	701EH
d0-31	Auxiliary frequency Y	0.01 Hz	701FH
d0-32	Viewing any register address value	1	7020H
d0-35	Target torque	0.1%	7023H
d0-37	Power factor angle	0.1°	7025H
d0-39	Target voltage upon V/F separation	1 V	7027H
d0-40	Output voltage upon V/F separation	1V	7028H
d0-41	DI state visual display	1	7029H
d0-42	DO state visual display	1	702AH
d0-43	DI function state visual display 1 (functions 01-40)	1	702BH
d0-44	DI function state visual display 2 (functions 41-80)	1	702CH
d0-45	Fault information	1	702DH
d0-59	Current set frequency	0.01%	703BH
d0-60	Current running frequency	0.01%	703CH
d0-61	AC drive running state	1	703DH
d0-62	Current fault code	1	703EH
d0-65	Torque upper limit	0.1%	7041H

4 Troubleshooting and Resolutions

4.1 Faults and solutions

The AC900 provides a total of 24 pieces of fault information and protective functions. After a fault occurs, the AC drive implements the protection function, AC drive output stops, and displays the fault code on the operation panel. Before seeking for technical support, you can first determine the fault type, analyze the causes, and perform troubleshooting according to the following tables. If the fault cannot be rectified, contact the agent or our company.

Err22 mentioned below is the AC drive hardware overcurrent or overvoltage signal. In most situations, hardware overvoltage fault causes Err22.

Fault Name	Display	Possible Causes	Solutions
Inverter unit protection	Err01	1: The output circuit is short circuited. 2: The connecting cable of the motor and the AC drive is too long. 3: The module overheats. 4: The internal connections become loose. 5: The main control board is faulty. 6: The drive board is faulty. 7: The inverter module is faulty.	1: Eliminate external faults. 2: Install a reactor or an output filter. 3: Check the air filter and the cooling fan and troubleshoot existing problems 4: Connect all cables properly. 5: Seek for technical support 6: Seek for technical support 7: Seek for technical support
Overcurrent during acceleration	Err02	1: The output circuit is grounded or short circuited. 2: vector control is presented and Motor auto-tuning is not performed. 3: The acceleration time is too short. 4: Manual torque boost or V/F curve is not appropriate. 5: The voltage is too low. 6: The startup operation is performed on the rotating motor. 7: A sudden load is added during acceleration. 8: The AC drive model is of too small power class.	1: Eliminate external faults. 2: Perform the motor auto-tuning. 3: Increase the acceleration time. 4: Adjust the manual torque boost or V/F curve. 5: Adjust the voltage to normal range. 6: Select rotational speed tracking restart or start the motor after it stops. 7: Remove the added load. 8: Select an AC drive of higher power class.

Fault Name	Display	Possible Causes	Solutions
Overcurrent during deceleration	Err03	1: The output circuit is grounded or short circuited. 2: Motor auto-tuning is not performed. 3: The deceleration time is too short. 4: The voltage is too low. 5: A sudden load is added during deceleration. 6: The braking unit and braking resistor are not installed.	1: Eliminate external faults. 2: Perform the motor auto-tuning. 3: Increase the deceleration time. 4: Adjust the voltage to normal range. 5: Remove the added load. 6: Install the braking unit and braking resistor.
Overcurrent at constant speed	Err04	1: The output circuit is grounded or short circuited. 2: Vector control is presented and Motor auto-tuning is not performed. 3: The voltage is too low. 4: A sudden load is added during operation. 5: The AC drive model is of too small power class.	1: Eliminate external faults. 2: Perform the motor auto-tuning. 3: Adjust the voltage to normal range. 4: Remove the added load. 5: Select an AC drive of higher power class.
Overvoltage during acceleration	Err05	1: The input voltage is too high. 2: An external force drives the motor during acceleration. 3: The acceleration time is too short. 4: The braking unit and braking resistor are not installed.	1: Adjust the voltage to normal range. 2: Cancel the external force or install a braking resistor. 3: Increase the acceleration time. 4: Install the braking unit and braking resistor.
Overvoltage during deceleration	Err06	1: The input voltage is too high. 2: An external force drives the motor during deceleration. 3: The deceleration time is too short. 4: The braking unit and braking resistor are not installed.	1: Adjust the voltage to normal range. 2: Cancel the external force or install the braking resistor. 3: Increase the deceleration time. 4: Install the braking unit and braking resistor.
Overvoltage at constant speed	Err07	1: The input voltage is too high. 2: An external force drives the motor during deceleration.	1: Adjust the voltage to normal range. 2: Cancel the external force or install the braking resistor.
Control power supply fault	Err08	1: The input voltage is not within the allowable range.	1: Adjust the input voltage to the allowable range.

Fault Name	Display	Possible Causes	Solutions
Undervoltage	Err09	1: Instantaneous power failure. 2: The AC drive's input voltage is not within the allowable range. 3: The bus voltage is abnormal. 4: The rectifier bridge and buffer resistor are faulty. 5: The drive board is faulty. 6: The main control board is faulty.	1: Reset the fault. 2: Adjust the voltage to normal range. 3: Seek technical support. 4: Seek technical support. 5: Seek technical support. 6: Seek technical support.
AC drive overload	Err10	1: The load is too heavy or locked-rotor occurs on the motor. 2: The AC drive model is of too small power class.	1: Reduce the load and check the motor and mechanical condition. 2: Select an AC drive of higher power class.
Motor overload	Err11	1: P9-01 is set improperly. 2: The load is too heavy or locked-rotor occurs on the motor. 3: The AC drive model is of too small power class.	1: Set the parameter correctly. 2: Reduce the load and check the motor and the mechanical condition. 3: Select an AC drive of higher power class.
Power input phase loss	Err12	1: The three-phase power input is abnormal. 2: The drive board is faulty. 3: The lightning board is faulty. 4: The main control board is faulty.	1: Eliminate external faults. 2: Seek technical support. 3: Seek technical support. 4: Seek technical support.
Power output phase loss	Err13	1: The cable connecting the AC drive and the motor is faulty. 2: The AC drive's three-phase outputs are unbalanced when the motor is running. 3: The drive board is faulty. 4: The module is faulty.	1: Eliminate external faults. 2: Check whether the motor three-phase winding is normal. 3: Seek technical support. 4: Seek technical support.
Module overheat	Err14	1: The ambient temperature is too high. 2: The air filter is blocked. 3: The fan is damaged. 4: The thermally sensitive resistor of the module is damaged. 5: The inverter module is damaged.	1: Lower the ambient temperature. 2: Clean the air filter. 3: Replace the damaged fan. 4: Replace the damaged thermally sensitive resistor. 5: Replace the inverter module.

Fault Name	Display	Possible Causes	Solutions
External equipment fault	Err15	1: External fault signal is input via DI. 2: External fault signal is input via virtual I/O.	1: Reset the operation. 2: Reset the operation.
Communication fault	Err16	1: The host computer is in abnormal state. 2: The communication cable is faulty. 3: reservation 4: The communication parameters in group Pd are set improperly.	1: Check the cabling of host computer. 2: Check the communication cabling. 3: Set communication expansion cards correctly. 4: Set the communication parameters properly.
Contactor fault	Err17	1: The drive board and power supply are faulty. 2: The contactor is faulty.	1: Replace the faulty drive board or power supply board. 2: Replace the faulty contactor.
Current detection fault	Err18	1: The HALL device is faulty. 2: The drive board is faulty.	1: Replace the faulty HALL device. 2: Replace the faulty drive board.
Motor auto-tuning fault	Err19	1: The motor parameters are not set according to the nameplate. 2: The motor auto-tuning times out.	1: Set the motor parameters according to the nameplate properly. 2: Check the cable connecting the AC drive and the motor.
EEPROM read-write fault	Err21	1: The EEPROM chip is damaged.	1: Replace the main control board.
AC drive hardware fault	Err22	1: Overvoltage exists. 2: Overcurrent exists.	1: Handle based on overvoltage. 2: Handle based on overcurrent.
Short circuit to ground	Err23	1: The motor is short circuited to the ground.	1: Replace the cable or motor.
Accumulative running time reached	Err26	1: The accumulative running time reaches the setting value.	1: Clear the record through the parameter initialization function.
User-defined fault 1	Err27	1: The user-defined fault 1 signal is input via DI. 2: User-defined fault 1 signal is input via virtual I/O.	1: Reset the operation. 2: Reset the operation.

Fault Name	Display	Possible Causes	Solutions
User-defined fault 2	Err28	1: The user-defined fault 2 signal is input via DI. 2: The user-defined fault 2 signal is input via virtual I/O.	1: Reset the operation. 2: Reset the operation.
Accumulative power-on time reached	Err29	The accumulative power-on time reaches the setting value.	Clear the record through the parameter initialization function.
Load becoming 0	Err30	1: The AC drive running current is lower than P9-64.	1: Check that the load is disconnected or the setting of P9-64 and P9-65 is correct.
PID feedback lost during running	Err31	1: The PID feedback is lower than the setting of PA-26.	1: Check the PID feedback signal or set PA-26 to a proper value.
Pulse-by-pulse current limit fault	Err40	1: The load is too heavy or locked-rotor occurs on the motor. 2: The AC drive model is of too small power class.	1: Reduce the load and check the motor and mechanical condition. 2: Select an AC drive of higher power class.
Motor overheat	Err45	1: The cabling of the temperature sensor becomes loose. 2: The motor temperature is too high.	1: Check the temperature sensor cabling and eliminate the cabling fault. 2: Lower the carrier frequency or adopt other heat radiation measures.
Initial position fault	Err51	1: The motor parameters are not set based on the actual situation.	1: Check that the motor parameters are set correctly and whether the setting of rated current is too small.

4.2 Common Faults and Solutions

You may come across the following faults during the use of the AC drive. Refer to the following table for simple fault analysis.

Table 4-1 Troubleshooting to common faults of the AC drive

SN	Fault	Possible Causes	Solutions
1	There is no display at power-on.	1: There is no power supply to the AC drive or the power input to the AC drive is too low. 2: The power supply of the switch on the drive board of the AC drive is faulty. 3: The rectifier bridge is damaged. 4: The control board or the operation panel is faulty. 5: The cable connecting the control board and the drive board and the operation panel breaks.	1: Check the power supply. 2: Check the bus voltage. 3: Re-connect the 34-core cables. 4: Contact our company for technical support.
2	"HC" is displayed at power-on.	1: The cable between the drive board and the control board is in poor contact. 2: Related components on the control board are damaged. 3: The motor or the motor cable is short circuited to the ground. 4: The HALL device is faulty. 5: The power input to the AC drive is too low.	1: Re-connect the 34-core cables. 2: Contact our company for technical support.
3	"Err23" is displayed at power-on.	1: The motor or the motor output cable is short-circuited to the ground. 2: The AC drive is damaged.	1: Measure the insulation of the motor and the output cable with a megger. 2: Contact our company for technical support.
4	The AC drive display is normal upon power-on. But "HC" is displayed after running and stops immediately.	1: The cooling fan is damaged or locked-rotor occurs. 2: The external control terminal cable is short circuited.	1: Replace the damaged fan. 2: Eliminate external fault

SN	Fault	Possible Causes	Solutions
5	Err14 (module overheat) fault is reported frequently.	1: The setting of carrier frequency is too high. 2: The cooling fan is damaged, or the air filter is blocked. 3: Components inside the AC drive are damaged (thermal coupler or others).	1: Reduce the carrier frequency (P0-15). 2: Replace the fan and clean the air filter. 3: Contact the agent or Inovance for technical support.
6	The motor does not rotate after the AC drive runs.	1: Check the motor and the motor cables. 2: The AC drive parameters are set improperly (motor parameters). 3: The cable between the drive board and the control board is in poor contact. 4: The drive board is faulty.	1: Ensure the cable between the AC drive and the motor is normal. 2: Replace the motor or clear mechanical faults. 3: Check and re-set motor parameters.
7	The DI terminals are disabled.	1: The parameters are set incorrectly. 2: The external signal is incorrect. 3: The jumper bar across OP and +24 V becomes loose. 4: The control board is faulty.	1: Check and reset the parameters in group P4. 2: Re-connect the external signal cables. 3: Re-confirm the jumper bar across OP and +24V. 4: Contact our company for technical support.
9	The AC drive reports overcurrent and overvoltage frequently.	1: The motor parameters are set improperly. 2: The acceleration/deceleration time is improper. 3: The load fluctuates.	1: Re-set motor parameters or re-perform the motor auto-tuning. 2: Set proper acceleration/ deceleration time. 3: Contact our company for technical support.
10	Err17 is reported upon power-on or running.	1: The soft startup contactor is not picked up.	1: Check whether the contactor cable is loose. 2: Check whether the contactor is faulty. 3: Check whether 24 V power supply of the contactor is faulty. 4: Contact our company for technical support.
11	88888 is displayed upon power-on.	1: Related component on the control board is damaged.	1: Replace the control board.

Appendix AC900 Communication Data Address

Function code group number	communication access address	Function code address while modifying RAM
Group P0-PE	0xF000-0xFEFF	0x0000-0x0EFF
Group E0-EC	0xA000-0xACFF	0x4000-0x4CFF
Group d0	0x7000-0x70FF	

Parameter address	Parameter description	Parameter address	Parameter description
1000H	Communication setting value(decimal)	1010H	PID setting
1001H	Running frequency	1011H	PID feedback
1002H	Bus voltage	1012H	PLC procedure
1003H	Output voltage	1013H	input pulse frequency, unit 0.01kHz
1004H	Output current	1014H	Feedback speed, unit 0.1Hz
1005H	Output power	1015H	Remaining running time
1006H	Output torque	1016H	AI1 voltage before calibration
1007H	Running speed	1017H	AI2 voltage before calibration
1008H	DI input flag	1018H	Reserved
1009H	DO output flag	1019H	linear speed
100AH	AI1 voltage	101AH	Present power-on time
100BH	AI2 voltage	101BH	Present running time
100CH	Reserved	101CH	input pulse frequency, unit 1Hz
100DH	Count value input	101DH	Communication setting value
100EH	Length value input	101EH	Actual feedback speed
100FH	Load speed	101FH	Principal frequency X display
--	--	1020H	Auxiliary frequency Y display

Command word address	Function
2000H	0001: forward running
	0002: reverse running
	0003: forward jog
	0004: reverse jog
	0005: free stop
	0006: decelerate to stop
	0007: fault reset

Input control commands into AV drive: (read only)

Status word address	Function
3000H	0001: forward running
	0002: reverse running
	0003: stop

Password check for locked parameters: (8888H indicates password validated)

Password address	Enter password
1F00H	*****

Digital output terminal control: (write only)

Command address	Command information
2001H	BIT0: DO1 output control
	BIT1: Reserved
	BIT3: RELAY1 output control
	BIT4: FMR output control
	BIT5: Reserved
	BIT6: Reserved
	BIT7: Reserved
	BIT8: Reserved
	BIT9: Reserved

Analog output AO1control: (write only)

Command address	Command information
2002H	0-7FFF correspond to 0%-100%

Pulse output control: (write only)

Command address	Command information
2004H	0-7FFF correspond to 0%-100%

AC drive fault description:

AC drive fault address	AC drive fault information	
8000H	0000: fault-free	0015: parameter read-write fault
	0001: reserved	0016: AC drive hardware fault
	0002: overcurrent during acceleration	0017: Short circuit to ground
	0003: overcurrent during deceleration	0018: reserved
	0004: overcurrent at constant speed	0019:reserved
	0005:Overvoltage during acceleration	001A: Accumulative running time reached
	0006: Overvoltage during deceleration	001B: User-defined fault 1
	0007: Overvoltage at constant speed	001C: User-defined fault 2
	0008: Buffer resistance overload	001D: Accumulative power-on
	0009: Undervoltage	001E: Load becoming 0
	000A: AC drive overload	001F: PID feedback lost during running
	000B: Motor overload	0028: fast current limit timeout fault
	000C: Power input phase loss	0029: Reserved
	000D: Power output phase loss	002A: Reserved
	000E: Module overheat	002B: Reserved
	0010: Communication fault	002D: Reserved

	0011: Contactor fault	005A: Reserved
	0012: Current detection fault	005B: Reserved
	0013: Motor auto-tuning fault	005C: Reserved
	0014: Reserved	005E: Reserved

Warranty Agreement

- 1) The warranty period of the product is 12 months (Bar code of the product shall prevail). If the product malfunctions or breaks down when it is used under normal conditions based on Operating Instruction and the product is within warranty period, our company shall repair it free of charge.
- 2) Our company shall charge certain fees for repair if the breakdown of the product is caused by the following reasons even though the product is within the warranty period:
 - A. Breakdown caused by wrong operation, unprofessional repair and transformation;
 - B. Breakdown caused by fire disaster, flood, abnormal voltage, other natural disasters and secondary disasters;
 - C. Hardware breakdown caused by man-made fall off and transportation issues after purchasing;
 - D. Breakdown caused by wrong operation that without the reference of *User's Manual* provided by our company;
 - E. Malfunction or breakdown caused by problems (such as problems of peripheral equipment) that have nothing to with the product itself;
- 3) When your product malfunctions or breaks down, please fill in your *Warranty Card* correctly and carefully.
- 4) The repair fees are based on our company's newly-adjusted *Price List of Maintenance*.
- 5) Each product just has one *Warranty Card*, please reserve the card carefully and take your card while repairing the product.
- 6) If you encounter any problems during the repair, please contact our company or its agents immediately.
- 7) ANCHUAN ELECTRONICS CO., LTD. reserves the right to interpret the agreement.

ANCHUAN ELECTRONICS CO., LTD.

Call of Customer Service Center: 400-886-9116

Website: www.anchuandz.com.cn



Warranty Card

Customer's Information	Company Address:	
	Company Name:	Contact:
	Post Code:	Phone Number:
Product Information	Product Model:	
	Bar Code of the Product (paste here):	
	Name of the Agent:	
Fault Information	(Time and Contents of Repair):	
	Repairmen:	